

TM ®

## WIRE-WAVE DETECTORS

for perimeters

"Impuls-mini1/500KS" "Impuls-mini 1/250KS"	OMLD. 04.003 -00
" Impuls-mini 1/500" " Impuls-mini 1/250"	OMLD. 04.003 -01
" Impuls-mini 1/500P" " Impuls-mini 1/250P"	OMLD. 04.003 -02

TU 4372-005-44873746-04

Manufacturer: **SIC "Omega-microdesign"**

## INSTALLATION AND OPERATION MANUAL

**OMLD. 04. 003 OM**

**RUSSIA**

# CONTENS

<b>1. INTRODUCTION.....</b>	<b>3</b>
<b>2. PURPOSE .....</b>	<b>3</b>
<b>3. TECHNICAL DATA .....</b>	<b>4</b>
<b>4. INSTALLATION AND OPERATION INSTRUCTIONS.....</b>	<b>5</b>
<b>5. CONTENTS OF DELIVERY .....</b>	<b>6</b>
<b>6. DESIGN AND OPERATION OF DETECTOR.....</b>	<b>7</b>
6.1 PRINCIPLE OF OPERATION .....	7
6.2 DETECTION AREA .....	7
6.3 SENSOR UNIT .....	9
6.4 THE UNITS DESIGN DESCRIPTION.....	10
6.4.1 TU and RU design.....	10
6.4.2 CCU design .....	10
<b>7. MARKING AND SEALING.....</b>	<b>13</b>
<b>8. BOXING AND PACKAGE .....</b>	<b>13</b>
<b>9. SAFETY PRECAUTIONS .....</b>	<b>14</b>
<b>10. ORDER OF INSTALLATION .....</b>	<b>14</b>
10.1 INSTALLING ON A BARRIER.....	14
10.2 INSTALLATION ON AN OPEN GROUND.....	16
10.3 LEAD WIRES AND CABLES .....	17
<b>11. SETTING UP THE DETECTOR.....</b>	<b>19</b>
11.1 TESTING OF POWER SUPPLIES OF THE DETECTOR.....	19
11.2 FUNCTIONAL TEST AND ADJUSTMENT OF THE DETECTOR.....	19
11.3 TRAINING OF THE DETECTOR .....	19
11.4 DETECTOR TRAINING PROCEDURE .....	20
11.5 TESTING OF THE DETECTOR .....	20
<b>12. MAINTENANCE SCHEDULE .....</b>	<b>21</b>
<b>13. STORAGE AND TRANSPORTATION RULES.....</b>	<b>22</b>
<b>14. TROUBLESHOOTING.....</b>	<b>22</b>

## 1. INTRODUCTION

1.1 The present manual covers the installation and operation rules related to wire-wave detectors “Impuls-mini1/500”, “Impuls-mini1/250”, “Impuls-mini1/500P”, “Impuls-mini1/250P”, “Impuls-mini1/500KS”, “Impuls-mini1/250KS”, TU 4372-005-44873746-04.

1.2 The following definitions and abbreviations are used for the purposes of this manual: **detector** – a wire-wave detector “Impuls-mini1/...”; **RU** – a receiver unit; **TU** – a transmitter unit; **CCU** – a connection and control unit; **SU** – a sensor unit; **LWg** – left wing; **RWg** – right wing; **UW** – the SU’s upper wire; **LW** – the SU’s lower wire; **SA** – sensitivity area; **DA** – detection area; **IPK** – installation parts kit; **WMA** – the SU’s wire mounting attachments; **CIU** – control and indicating unit.

1.3 The two-wing wire-wave detector “Impuls-mini1/500...” comprises two SUs as two-wire lines mounted on dielectric consoles or supports, two pairs of RUs and TUs, a CCU, and three or four earthrods depending layout of units along the guarded perimeter.

1.4 The RUs of both wings are connected to the CIU, starts of the SU, and, if the CCU is at a distance from the RUs, the earthrods.

1.5 The TUs are connected to the ends of the SU, and the earthrods.

1.6 The spatial DA (section A, Fig.1.1, Fig.1.2) is formed around the SU’s wires and follows all the turns and heights variations there of.

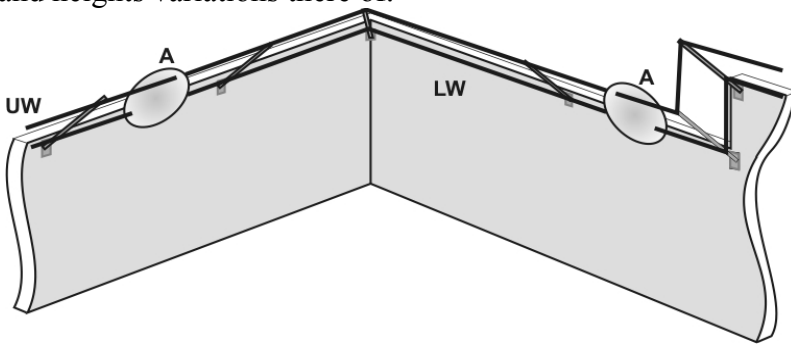

fig. 1.1

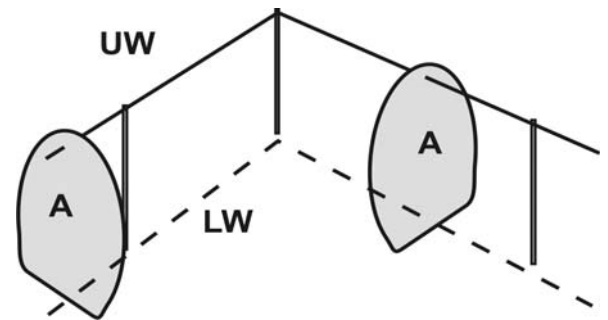

fig. 1.2

## 2. PURPOSE

2.1 The detector is designed to form and monitor an extended spatial DA with turns and various heights, and to generate an alarm signal in case of intruder detection in the DA.

2.2 The SU follows the turns and height variations along a rugged terrain aligning the DA with the roughness of the guarded perimeter.

2.3 Depending on application the DA can be formed:

a) in the upper part of a barrier: a “canopy-type” version with any pitch (Fig. 2.1a), where the UW and the LW are attached to the dielectric consoles (IPK1 or IPK2);

b) along the barrier, as to monitor breaching, getting over or undermining, where the UW is attached to the dielectric consoles (IPK3), and the LW is buried 5 to 10 cm. underground (Fig. 2.1b);

c) along the ground surface (Fig.2.1c), where the UW is attached to the dielectric supports (IPK4), and the LW is buried 5 to 10 cm. underground;

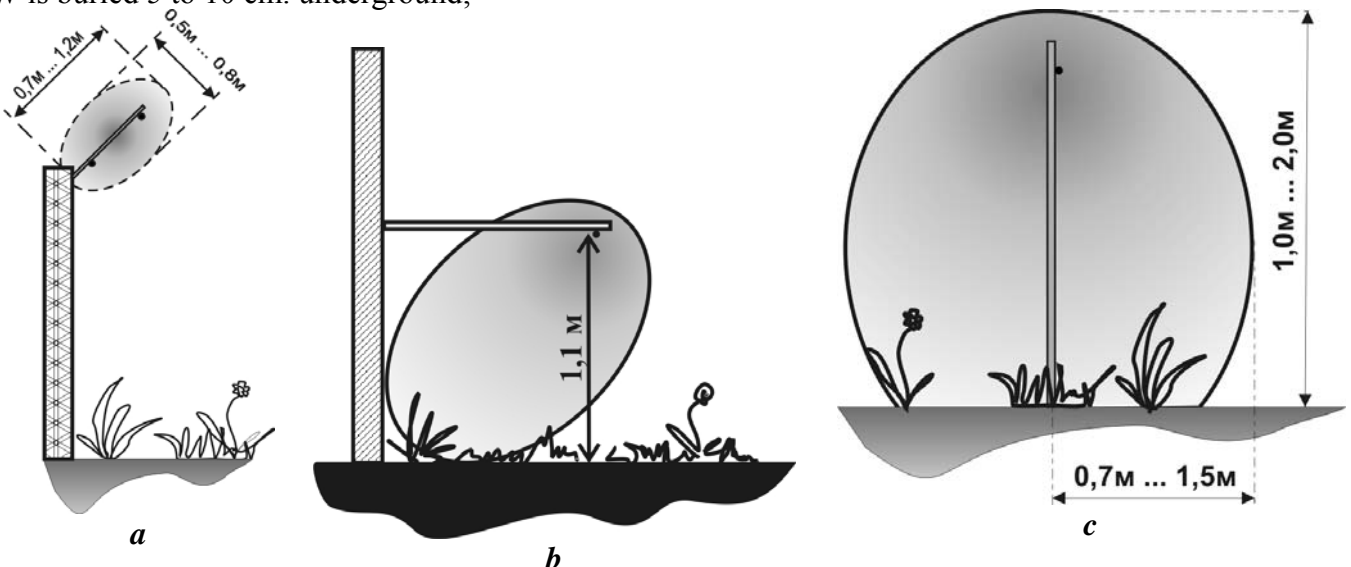

Fig. 2.1

2.4 If necessary, physical obstacles can be included into the DA (a barbed wire net AKL, Fig.2.2, barbed wire, etc.). At that the DA must be free of long metal pieces, as false operation due to swinging or rain may occur.

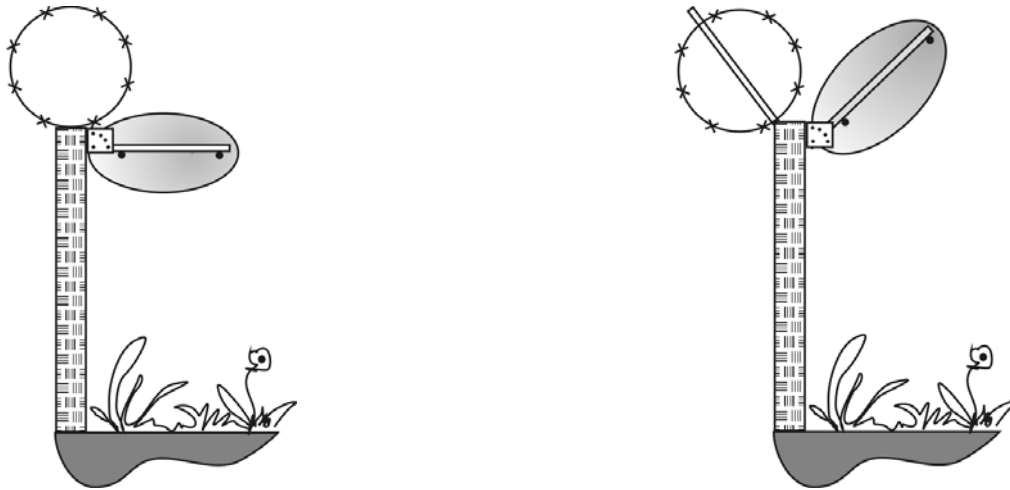

Fig. 2.2

### **3. TECHNICAL DATA**

3.1 The detector maintains continuous round the clock operation.

3.2 The detector is capable of forming a two-wing spatial detection area with a length from 40 m to 500 m long (from 20 m to 250 m for each wing). Usage of one wing is possible as displayed in the detector's designation by means of the numbers: "250" or "500".

3.3 The detector is capable of safe operation in temperate or cold climate (Temperate and Cold Climate (UHL) construction, category 1 under GOST 15150-69, yet in the temperature range from -50°C to + 50°C).

3.4 The detector is capable of safe operation at wind velocities of up to 30 m/sec and rainfall of up to 30 mm/hr.

3.5 The detector is powered from a power supply unit with rated voltage of 24VDC at permissible voltage fluctuations:

<b>"Impuls-mini1/500", "Impuls-mini1/250", "Impuls-mini1/500KS", "Impuls-mini1/250KS"</b>	<b>20 V ... 36 V</b>
<b>"Impuls-mini1/500P", "Impuls-mini1/250P"</b>	<b>11 V ... 36 V</b>

3.6 Peak current drawn by the detector in the direct or alternating current lines will not exceed 60mA, for the two wings, where the maximum power consumption will not exceed 0.7W for the two wings.

3.7 The detector is capable of generating an ALARM signal in the monitoring circuit with lasting from 2 to 5 sec. An ALARM signal is generated through a change of the monitoring output circuit resistance from less than 350ohms to more than 1000kΩ, or through "interruption" of an external control resistor Rtr positioned into terminals at the face plate of the RU. Upon the change of the monitoring output circuit resistance the voltage must not exceed 38V, and the current must be limited at a level of no more than 100mA. It is possible to connect control indicators on the face panel of the RU, which will be used when making adjustments.

3.8 The detector is capable of generating an ALARM signal and relevant indication on the RU's face panel in case of intrusion attempts within the DA, opening or shorting of the SU's wires.

3.9 The detector is capable of generating a continuous ALARM signal in case of power supply interruption.

3.10 Generation of an ALARM signal on touching the detector's units, the SU's wires and earthing is allowed.

3.11 The detector is capable of remote control of its operation. A remote control signal must be generated by means of sending a direct-voltage pulse (within the power supply voltage of the detector) to the DK (Remote Control) contacts of the RU's terminals that will have a length of no less than 0.5 sec. (fig.3.1). In case of healthy operation the detector will answer the DK signal by generating an ALARM signal.

3.12 The detector is equipped with integral single-level protection from voltage induced by lightning or other electrical discharges, where the said protection covers all the external circuits of up to 500 m long connected to the RU's terminals. Protection of input circuits activates when input voltages exceed a value of ~39...40V. However, if the length of the lines connected to the RU's terminals exceeds 500 m it is required to use KSUM (universal junction box) distribution boxes with lightning-discharge protection.

3.13 Service life of the detector units and the fiberglass WMAs will not be less than 10 years.

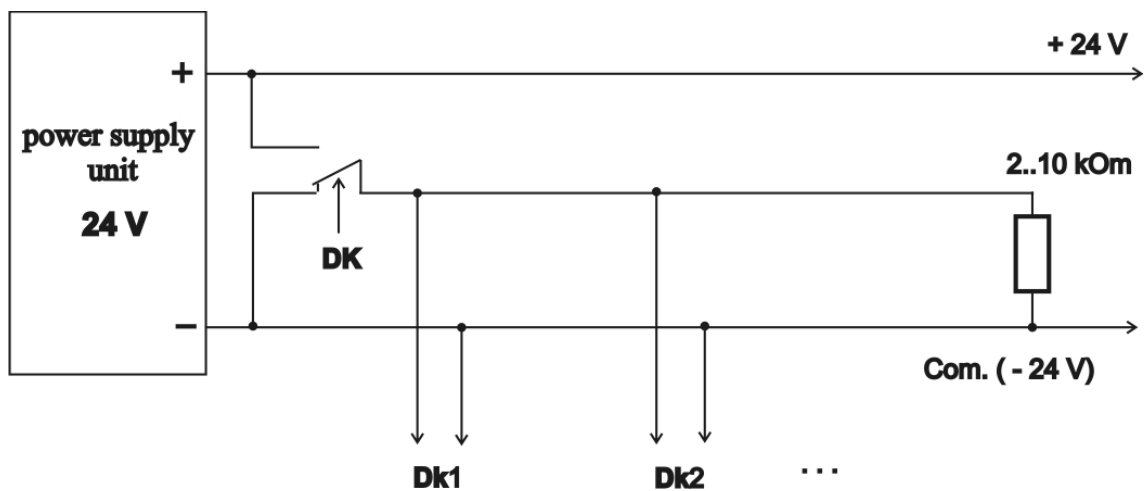

Fig. 3.1

#### 4. INSTALLATION AND OPERATION INSTRUCTIONS

4.1 Each wing of the detectors SU is placed at the guarded perimeter and incorporates two wires: the upper (signal) and the lower (common) respectively marked as “BIT” (UW) and “HIT” (LW). Sensitivity of the detector decreases with distance from the UW.

4.2 The DA’s cross-section is an ellipse with its long axis in the plane of the SU’s wires or in a plane that includes the UW and a perpendicular to grade.

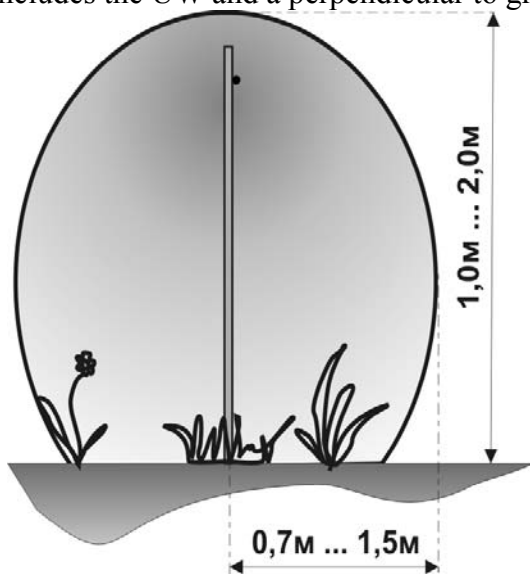

Fig. 4.1

4.3 If installed on an open ground, where the DA is formed along the grade, the UW shall be located at a height of no more than 1.8 m above grade, the LW shall be buried 5 to 10 cm. underground or located at a required height. A UW shall be a cupriferous wire of adequate strength and durability, for example, type P-274, or uninsulated bimetal, for example, BSM-1. A LW shall be of P-274 type or other cupriferous wire of adequate strength, durability and insulating properties. If the LW is installed on dielectric consoles, i.e. without a direct contact with ground or barrier, the said wire, in the same way as the UW, will not necessarily have an insulation coating.

4.4 The UW shall be attached to dielectric supports if the perimeter is guarded without a barrier; or to dielectric consoles arranged on a barrier, pole, trees, walls of buildings, etc. by means of plastic clamps.

4.5 The UW can be installed at a height exceeding 1.8 m, for example, on the upper part of the barrier. At that the DA will move up accordingly following the UW (the DA concentrating and contracting around and gradually forming into a circle with the UW as the center).

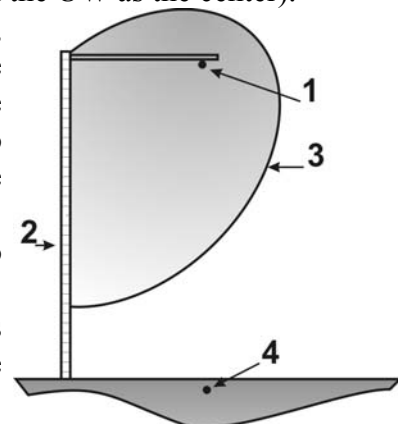

Fig. 4.2

4.6 If a UW 1 is installed close to a conducting barrier 2 (a steel mesh, grate, reinforced concrete panels, etc.), as shown in Fig.4.2, a DA 3 can be concentrated between the UW 1 and the barrier 2, where the LW 4 may be ignored. Therefore, the UW must be moved away from the barrier as to make the distance from the said wire to the grade smaller than that to the barrier.

4.7 The LW may be raised so as to approximate it to the UW in order to limit the section of the DA concentrated between the SU’s wires.

4.8 It is necessary to bear in mind that closely located cupriferous wires and cables parallel to the UW can be recognized by the detector as false LWs, where the DA may be formed between the UW and the false LW.

4.9 It is necessary to bear in mind that only the UW must be a single wire, where in case of a buried LW usage of a twisted pair is allowed, in which case the LW’s conductors shall be connected parallel with each other.

4.10 The UW and the LW must not have a swing of more than 5 cm in the wind, neither must they touch cases of the units and other objects.

4.11 Presence of swinging trees and other moving conducting objects at a distance of less than 1.5 to 2 m is not allowed as movement thereof may cause an ALARM signal generation. Presence of any moving objects in the DA is not allowed, including any vegetation taller than 0.3 m, except for single bents at a distance of less than 0.5 m from the UW.

4.12 A distance from the UW to the barrier, the structure of which contains conducting or metal elements, must be larger than that between the SU's wires or between the UW and the grade.

4.13 When forming a near-the-ground DA, the UW must be located no closer than 0.7 m from the barrier (the structure of which contains conducting or metal elements) or the wall of a building. At that the following condition must be strictly observed (4.6).

4.14 A close presence of poles, tree-trunks and other conducting objects near the UW in the DA will increase signal loss in the circuit and reduce maximum length of the guarded perimeter; a UW used without an insulation coating will reduce signal loss in the circuit.

4.15 Proximity of the UW of the SU to the ground surface and conducting barriers will also significantly increase signal loss and reduce maximum length of the guarded perimeter.

4.16 Proximity of the UW of the SU to barbed wire barriers with a distance of less than 1 m (if the distance to the LW is larger than that to the barbed wire) will increase signal loss by almost one third and therefore reduce maximum allowed length of the guarded perimeter.

4.17 Proximity of the UW of the SU to conducting barriers with a distance of less or approximately equal to the distance to the LW will cause deformation of the DA (see Fig.4.2), which may lead to false operations under rain or gusts.

4.18 Increasing the distance from the SU to the ground surface or to conducting barriers will decrease signal loss, where the same decrease occurs at increasing the distance from the LW to the ground surface or to conducting barriers, locating the LW closer to the UW.

4.19 Proximity of the UW to the non-conducting surface of snow cover will in no manner affect the formation of the DA. At that it is necessary to bear in mind that with formation of snow crust a possibility of unmonitored trespassing over the DA employing the high snow cover. Also, a certain reduction of sensitivity is possible resulting from distortion of the DA caused by the UW becoming closer to a conducting surface due to wet film formation on the snow cover.

4.20 Earth terminals located on the cases of the units must be connected by means of an isolated conductor to the earthrods placed in the ground as close as possible to the projections of the units and having a spreading resistance of no more than 30 Ohm. At that the cases of the TU and RU must not come in contact with the barrier.

4.21 The earthing conductor must be of any isolated copper wire with cross-section of 0.5 mm<sup>2</sup>, to be properly connected with the earthrod, to be installed along a shortest path, without coming into contact with foreign objects from the earth terminal on the unit to the earthrod's terminal located as close as possible to the ground surface.

4.22 The length of a guarded perimeter must not exceed 250 m and shall not be less than 25 m.

4.23 It is prohibited to connect to the terminals of the detector transmission lines having voltage of more than 36V. If the ALARM circuit is monitored the current on the "TP" (ALARM) terminals of the RU must be limited to a value not exceeding 20mA.

## **5. CONTENTS OF DELIVERY**

5.1 Contents of delivery for a detector and IPK to be chosen from tables corresponding to the packages.

	"Impuls-mini1/500..."	"Impuls-mini1/250..."
a transmitter unit (TU)	2 ea.	1 ea.
a receiver unit (RU)	2 ea.	1 ea.
a connection and control unit (CCU)	1 ea.	1 ea.
Passport	1 ea.	1 ea.
Installation and operation manual	1 ea.	1 ea.
Package	1 ea.	1 ea.

"IPK1" (WMA-01P) – for guarding a sector of perimeter using dielectric poles or barriers to attach the SU's wires.

Holder, 0.3 m consoles, clamps, washers, screws, nuts	set
Package	1 ea.

“IPK2” (WMA-02P) – for guarding a sector of perimeter using dielectric poles or barriers to attach the SU’s wires.

Holders, 0.75 m consoles, clamps, washers, screws, nuts	set
Package	1 ea.

“IPK3/1,2” (WMA-03P/1,2) – for guarding a sector of perimeter using barriers to attach the SU’s wires.

Holders, 1.2 m consoles, clamps, washers, screws, nuts	set
Package	1 ea.

“IPK3/1,5” (WMA-03P/1,5) – for guarding a sector of perimeter using barriers to attach the SU’s wires.

Holders, 1.5 m consoles, clamps, washers, screws, nuts	set
Package	1 ea.

“IPK4” (WMA-04P) – for guarding an open sector of perimeter without barriers or along conducting barriers.

Holders, 1.8 m supports, clamps, washers, screws, nuts	set
Package	1 ea.

*Notes:* 1) TU and RU can be installed on a barrier, on an “end” attachment point IPK-0...PK or directly on a earthrod; 2) To install on a barrier use an adaptor holder; 3) An IPK-04PK simultaneously functions as an earthrod.

**Earthrods** – are designed for earthing the detector’s units.

Earthrod	2 ea.
A RU attachment plate	1 ea.

**Wire sensing elements**

SU-1/250	Two insulated wires, 250 m each.	250 M
SU-3/250	Two (uninsulated and insulated) wires, 250 m each.	250 M

**6. DESIGN AND OPERATION OF DETECTOR**

**6.1 Principle of operation**

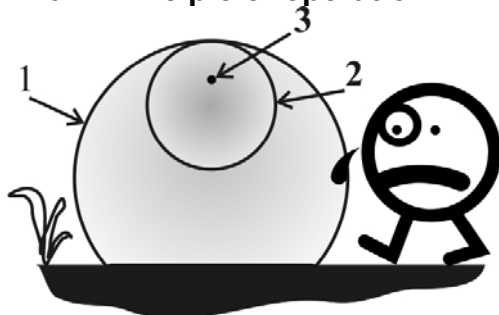

Fig. 6.1

6.1.1 The detector’s principle of operation is based on detecting a trespasser by an induced change of parameters of the electromagnetic field between a TU and a SU along a two-wire SU. At that the TU and RU units are connected to the opposite ends of the two-wire SU.

6.1.2 Two independent DA are formed along the SU: the main, 1 (see fig. 6.1), adjustable in its cross-section within the range of 0.5 to 2 m, and the secondary, 2, adjustable in its cross-section within the range of 0.1 to 0.8 m. (3 – UW). A signal processing algorithm includes two channels: the main, and the secondary

combined using an “OR” logic. Both channels equally generate an alarm signal unless turned off at a face panel of a RU of one or both channels. The main channel analyses the area of DA overlapped by a trespasser and a rate of motion of the latter. The main channel, as its name implies, bears the main load in detecting trespassers moving through the DA “all the way”, “two-double”, “on haunches”, “on all fours”, etc. (when set accordingly). It is necessary to bear in mind that with large cross-sections of the DA wind shaken vegetation or other moisture containing or conducting objects may enter it to cause a decreased interval between false alarms. The cross-section of the DA will be even larger for closely moving vehicles of other large-size machinery. The secondary channel analyses only the cross-section overlapped by the trespasser and is set mainly to detect an “all the way” running trespasser with the near-the-ground (open) version of the SU, or a trespasser moving over the canopy-type version of the SU. The DA cross-section of the secondary channel therefore must be as small as possible (not larger than required).

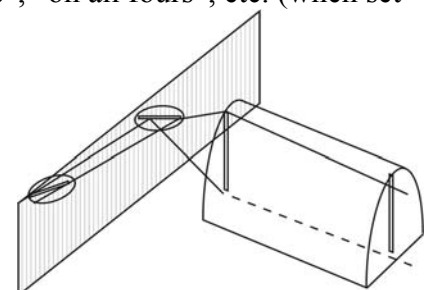

Fig. 6.2

**6.2 Detection area**

A cross-section of a DA can be from small (0,3m×0,3m), as to monitor the upper part of a barrier (for the main and the secondary channels), to maximum (2m×2m), as to monitor the perimeter at the ground surface (for the main channel only). The DA cross-section may be chosen for the entire SU of the detector or for a part of its sector, i.e. the DA will change following the change in the spacing between the SU’s wires, as

shown in fig. 6.2. However, the cross-sections of the DA must be chosen also depending on a condition of the guarded perimeter. The determining factor for cross-sections of the DA will be a distance between the UW and the LW or between the UW and the conducting surface (the ground). The condition of the guarded perimeter must conform to the set cross-section of the DA. If large-size metallic objects (steel or reinforced concrete poles, etc.) are present at the guarded perimeter it is necessary to install the detector's SU so as the distance from the UW to a metallic object is not less than 1.1 times longer than that from the UW to the LW (for the canopy-type version), or from the UW to the ground surface (for the near-the-ground version). The LW must always be located closer to the UP as compared with other foreign metallic objects (barbed wire, re-

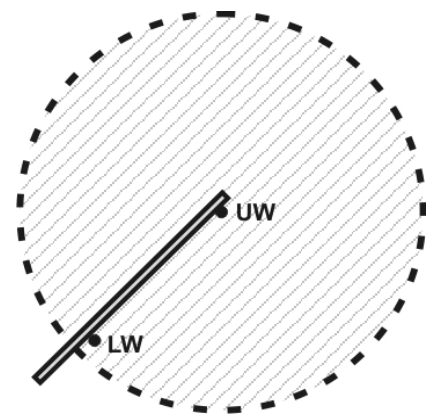

Fig. 6.3

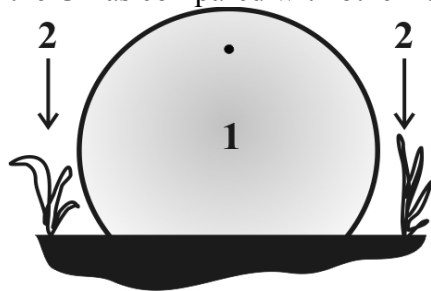

Fig. 6.4

inforcement, etc.). The zone within the dotted line (see fig.6.3) must not contain any conducting objects (except for the ground surface). In any case, the distance from the UW to a metallic object (a pole, a support used, for example, for attaching the UW of both wires) must not be less than 0.3 m. Moving objects (vegetation, animals, etc.) must not be within the DA. Thus, for the near-the-ground location, vegetation swinging in the DA or the DA crossed by an animal weighing more than 5 kg may degrade the signal-to-noise ratio and lead to false operation. Grass or bushes at the guarded perimeter will significantly influ-

ence the choice of the DA's cross-section. Battle or moist stems and branches when swinging under wind will induce noise in the receiver that may have a spectrum close to that of the legitimate signal and therefore cause "false" alarms. There are two ways to control these "false" alarms: 1) to cut the grass within the DA, as shown in fig. 6.4; 2) to retrain the detector, where an operator will cross the perimeter so that his body center of gravity is above the vegetation, thus decreasing the DA's cross-section (see fig. 6.5) until the swinging grass of bushes do not interfere with it, and accepting a possibility of "permitting" trespassers under the DA. Larger bushes are easier to handle: they can be slinged to stop

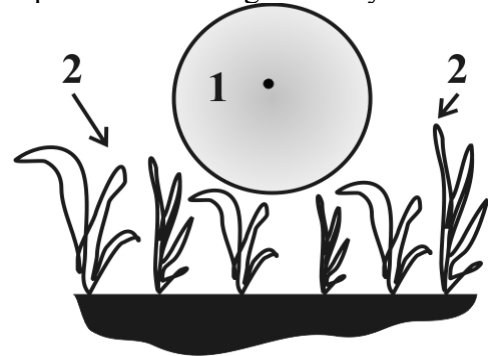

Fig. 6.5

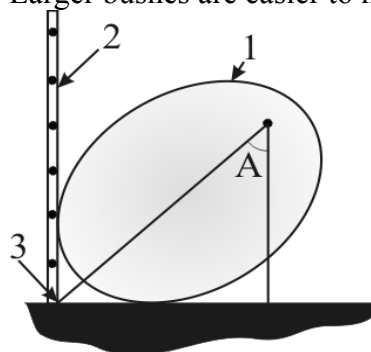

Fig. 6.6

them from swinging under wind. Majority of manufacturers of detectors with electromagnetic sensitivity area, allow for a certain height of vegetation within the DA by hardware limitation of the DA cross-section so that it does not cover the vegetation. At that the possibility of unmonitored passing under the DA can be eliminated using a barbed wire or net; however it creates big problems with maintenance of the guarded perimeter. As it was mentioned in article 4, when locating the UW close to a conducting barrier of a steel mesh 2 (grates, reinforce concrete panels, etc.), as shown in fig. 6.6, the detection area 1 will be concentrated between the UW, the ground and the barrier. Therefore, the UW of the SU must be at a sufficient distance from the barrier as to make the distance from the said wire to the

grade smaller than that to the barrier. The fig. 6.6 below shows an arrangement, where the distances from the UW to the grade and to the conducting barrier are approximately equal, so the angle  $A \approx 45^\circ$ . As shown the DA looks attracted by the line of intersection of the barrier with the ground. Though the example is rather conventional (as it does not take account of the conductance of the ground surface and the barrier), it, however, helps evaluate possible distortions of the DA. The fig.6.7 schematically shows tendencies of inclination of the axis of the DA's ellipse when the UW is moved away from the barrier (zone 2) or the UW moved closer to the barrier (zones 3, 4) relative to the DA 1 identical to that shown in the fig.6.6. The DA must be free of swinging or chattering barbed wire or other loosely attached metal objects, as

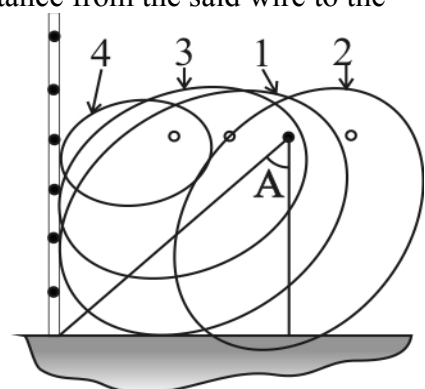

Fig. 6.7



these may cause false operations. By adjustments the cross-section of the DA must be limited so as to stop the noise induced in the signal processing channels (blinking of the LED on the face plate of the RU) by the swinging or chattering of the barbed wire of the SU's wires relative to the barbed wire. As it was mentioned above, anything relating to the influence from the barbed wire also relates to any other metal objects at the guarded perimeter (loosely attached metal sheets, parts of wires, mesh, etc.). When arranging a DA in a forest or a park (see fig. 6.8), the UW 1 of the SU must be located at a tactically chosen height observing all the recommendation set forth herein. Grass, bushes, branches of trees and other intensively swinging vegetation as well as animals moving within the DA 2 will increase the bio-noise and lead to false operations. To avoid such inconveniences either the cross-section of the DA must be decreased to the size 3 shown in the fig.6.8, or the grass must be cut, bushes and young trees knitted up, access of animals (weighing more than 5 kg) restricted.

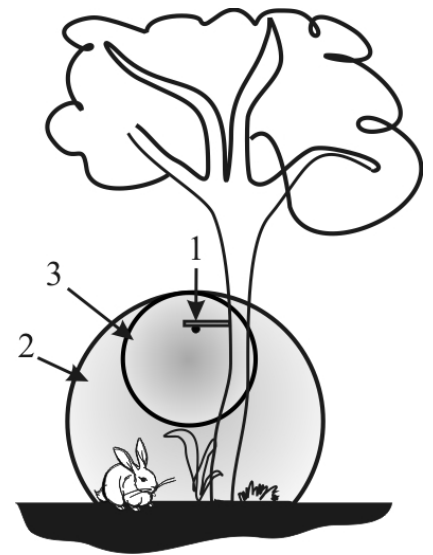

Fig. 6.8

### 6.3 Sensor unit

6.3.1 A two-wire SU along with a TU and a RU, is designed to form a spatial DA at the guarded perimeter.

6.3.2 For the near-the-ground version, the UW will be located at a height (1.0 to 1.8 m) from the ground surface, the LW buried 5 to 10 cm underground below the UW, or located at a chosen height.

6.3.3 The spatial DA is formed around the SU's wires, concentrates along them and has a cross-section of a truncated ellipse, depending on the conductance of the ground. Variants to build a SU and a DA cross-section are shown in the fig.6.9.

6.3.4 Supports of a non-conducting material (fiberglass or well impregnated wood coated with water-repellant paint) are mounted on holders installed at the perimeter with a spacing of 3 to 5 m.

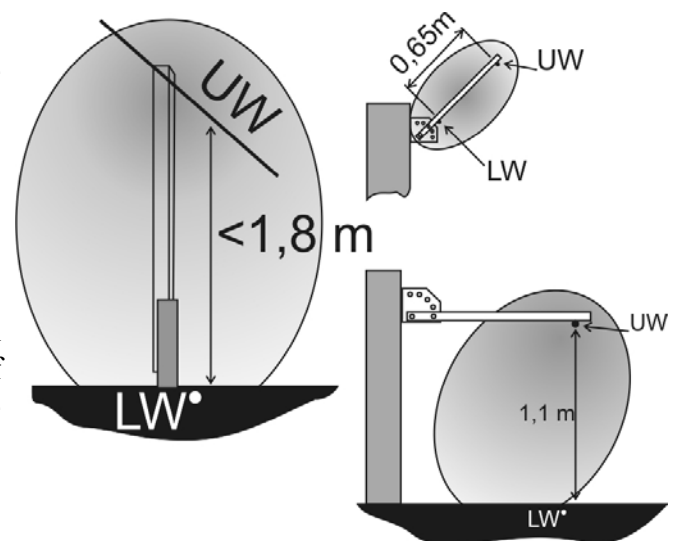

Fig. 6.9

6.3.5 If it is necessary to make a DA along a barrier or using the poles and tree-trunks existing along the perimeter, the SU will be installed using an IPK1 (with stub consoles), IPK2 (standard), and IPK3 (reinforced, with extended consoles). In such case the UW of the SU will be installed on dielectric consoles, which are attached to the barrier of the poles by means of appropriate holders.

6.3.6 The design of the holder allows choosing any inclination of a console from  $0^\circ$  to  $90^\circ$  in steps of  $\sim 22^\circ$  (fig.6.10). The inclination can be easily changed depending on the task to be solved and properties of the barrier's construction.

6.3.7 The SU's wires are attached to supports and consoles using clamps, by means of screws or wood screws.

6.3.8 The LW is located between the TU and the RU and is attached either to the lower part of a console or at a chosen distance from the ground surface, or in case of near-the-ground location of the DA, is buried to a depth of 5 to 10 cm, where it will significantly ease maintenance of the perimeter (removal of snow, cutting of grass).

6.3.9 The UW is attached to the upper part of supports or consoles, in parallel to the LW.

6.3.10 The slack of the wires in the middle of span between two neighboring consoles must not exceed 50 mm.

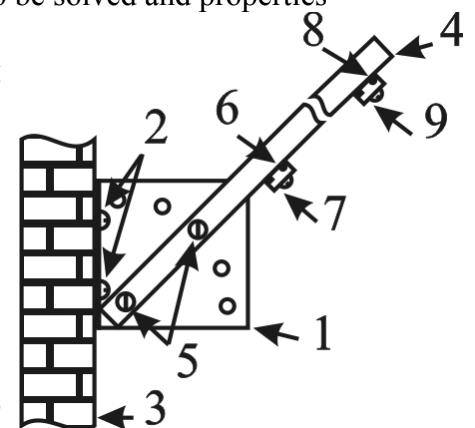

Fig. 6.10

## 6.4 The units design description

### 6.4.1 TU and RU design

6.4.1.1 A printed circuit board based sub-unit is installed in a cylindrical steel case (see fig. 6.11). On the cylinder of the case a plate for attaching the unit to a console or support from an IPK (variant 1), to an earthrod (variant 2), or to a special holder for attaching to a barrier or a wall of a building (variant 3) is arranged. A terminal for the TU (RU) earthing is arranged on the said plate. Contacts for connection of the UW and the LW are arranged on the end surfaces of the case and protected from weather impacts by means of protective caps. A lead-in of the lower wire is on an end surface with a designation strip with the serial number of the TU (RU) on it.



Fig. 6.11

6.4.1.2 The SU's wires are connected to the "БП" (UW) and "НП" (LW) contacts by means of screws and washers. In order to prevent ingress of moisture into the cases the UW must be fixed by means of a pressure-seal feed-through of the protective cap. The pressure-seal feed-through ensures protection from ingress of moisture on to the "БП" (UW) contact and the uninsulated part of the SU wire. At that a free drainage of water condensate from inside of the TU's (RU's) case must be ensured through the lower wire's lead-in. Therefore it is not required to seal the LW lead-in, where some inclination towards the marked side of the case when installing should be maintained. This can be done in three ways: by inclining the end console holding the unit; 2) by installing the unit onto an earthrod; 3) by installing the unit on a barrier.

6.4.1.3 The difference in construction of the RUs and that of the TUs is that a cable for connection with the CCU is lead out from the lower end part of the case.

### 6.4.2 CCU design



Fig. 6.12

6.4.2.1 The CCU connection and control unit is designed for distribution of cables of the transmission lines and connection of two RUs of adjacent wings. CCU is comes in two modifications. "Impuls-mini1...", "Impuls-mim1...P" modifications are furnished with a cylindrical case. "Impuls-mini1...KS" modification, besides the shape of its case, differs in that the CCU-KS incorporates a function of a distribution box (Connection Box), i.e. has an additional function of a transmission lines relay (allows for relaying of up to 20 or up to 40 lines). The CCU-KS (see fig. 6.12) comes with "Impuls-mini1/...KS". All the modifications

of CCU incorporate a converter with stabilized voltage output of 12V to supply two RUs. CCU-KS (see Fig. 6.13) is enclosed in an aluminum case 1 with a swing cover. The cover is attached by means of four thin shank coarse thread screws. The cover is sealed using a rubber gasket. A removable chassis 2 attached to the case by means of two thin shank coarse thread screws 3. A printed circuit board is attached to the back of the chassis. Access to "RU-LWg" and "RU-RWg" («БПРМ-ЛФ» and «БПРМ-ПФ») terminal sets to connect the RUs of the left and the right wings on the printed circuit board is implemented through windows in the chassis. On the back of the chassis there are terminal sets to connect jumper wires arranged. An "ON" («ВКЛ») toggle switch to turn the converters power voltage

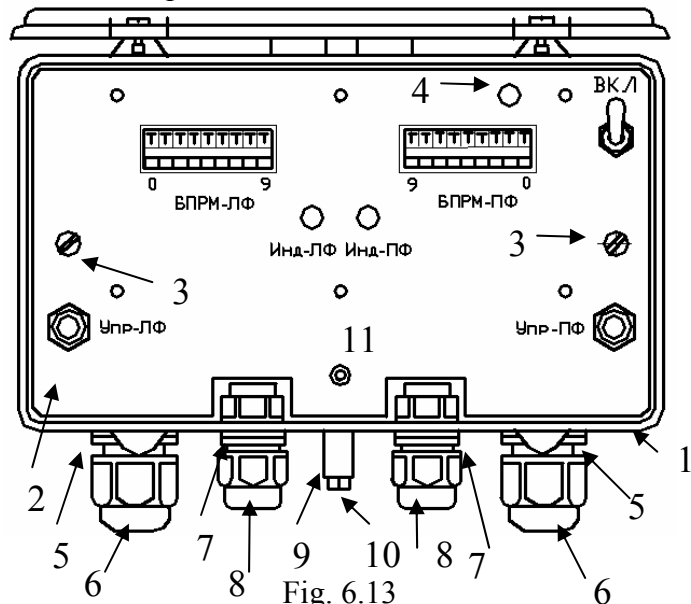

Fig. 6.13

of 12V (indicator 4), two control buttons "Ctrl-LWg" and "Ctrl-RWg" («Упр-ЛФ» and «Упр-ПФ»), and two indicators "Ind-LWg" and "Ind-RWg" («Инд-ЛФ» and «Инд-ПФ») of operation modes corresponding to the left and to the right wings are arranged directly of the chassis. A converter's output voltage presence indicator is also installed. In the base of the box there are glands lead-in 5 (7) with a sleeves-nut 6 (8) for feeding a CIU and connection cables of two RUs into the switching compartment, and a terminal 9 to connect an earthing wire attached by means of a bolt 10. A tamper sensor 11 is arranged on the chassis.

The following is shown on the functional diagram of the CCU-KS (fig. 6.14):

Cable 1 (кабель 1) – jumper cables;

Cable 2 (кабель 2) – jumper cables;

БПРМ-ЛФ (БПРМ-ПФ) - terminals to connect 8-conductor cables;  
 SB1- a button that opens the circuit when the CCU cover is open;  
 XT1, XT2, XT3, XT4 – terminals to connect jumper cables;  
 XT5 - terminal to connect control resistors and jumper cables;  
 «TP1» (LWg), «TP2» (RWg) - alarm signal terminals to connect CIU;  
 «RTP1» (LWg), «RTP2» (RWg) - pairs of terminals to connect control (terminal) resistors that define the “monitoring” mode of the CIU;  
 «SB1» - terminals to connect unit’s cover status (opened/closed) buttons;  
 SA1 «12 В» – RU’s power toggle button;  
 CY – control and power supply circuit (with indicator);  
 SB 2 «Упр-ЛФ» (SB 3 «Упр-ПФ») - control buttons;  
 HL1 «Инд-ЛФ» (HL2 «Инд-ПФ») - indicators;  
 FA...- lightning protection elements;  
 «Сл1»...«Сл6» – service lines;  
 «24 В» - power supply (voltage of direct or alternating current);  
 «ДК» - Remote Control contacts.

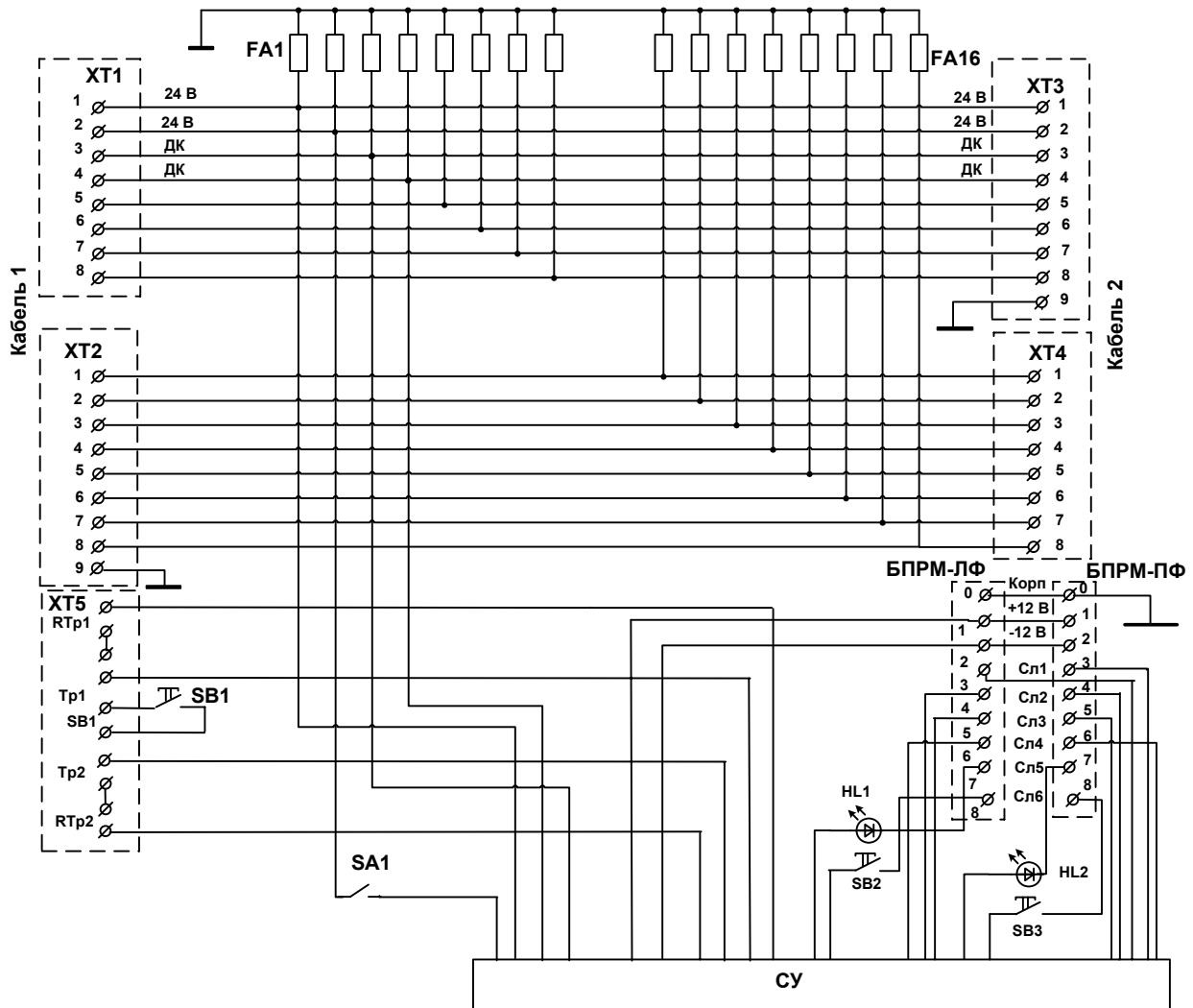

Fig. 6.14

When the cover starts opening a rod is released and contacts of the button open. In the lower part of the case there are lead-ins 5 (fig. 6.14) for jumper cables and pressure nut 6 to provide fastening of cables and tightness of the lead-in point. The tightness is given by compression of a rubber washer when the pressure nuts are tightened. The lead-ins 7 with the pressure nuts 8 are used for the units’ cables RUs. Earthing CCU-KS is implemented through a terminal 9 using an insulated cable of 3 to 4 mm in diameter. The earthing wire is fastened by a bolt 10. For protection from electromagnetic fields and inductions the shielding wire must be connected: a) for jumper cables – to terminals 9- XT2, b) for RU cables – to terminals 0-XT6. At that the earthing terminal of the CCU-KS case must be connected with the earthrod to provide secure operation and safe maintenance of the detector.

*Note.* To increase a number of circuits in a relayed cable, an additional optional printed circuit board (see fig. 6.15) with sets of terminals for relaying of 24 lines can be installed in the CCU-KS.

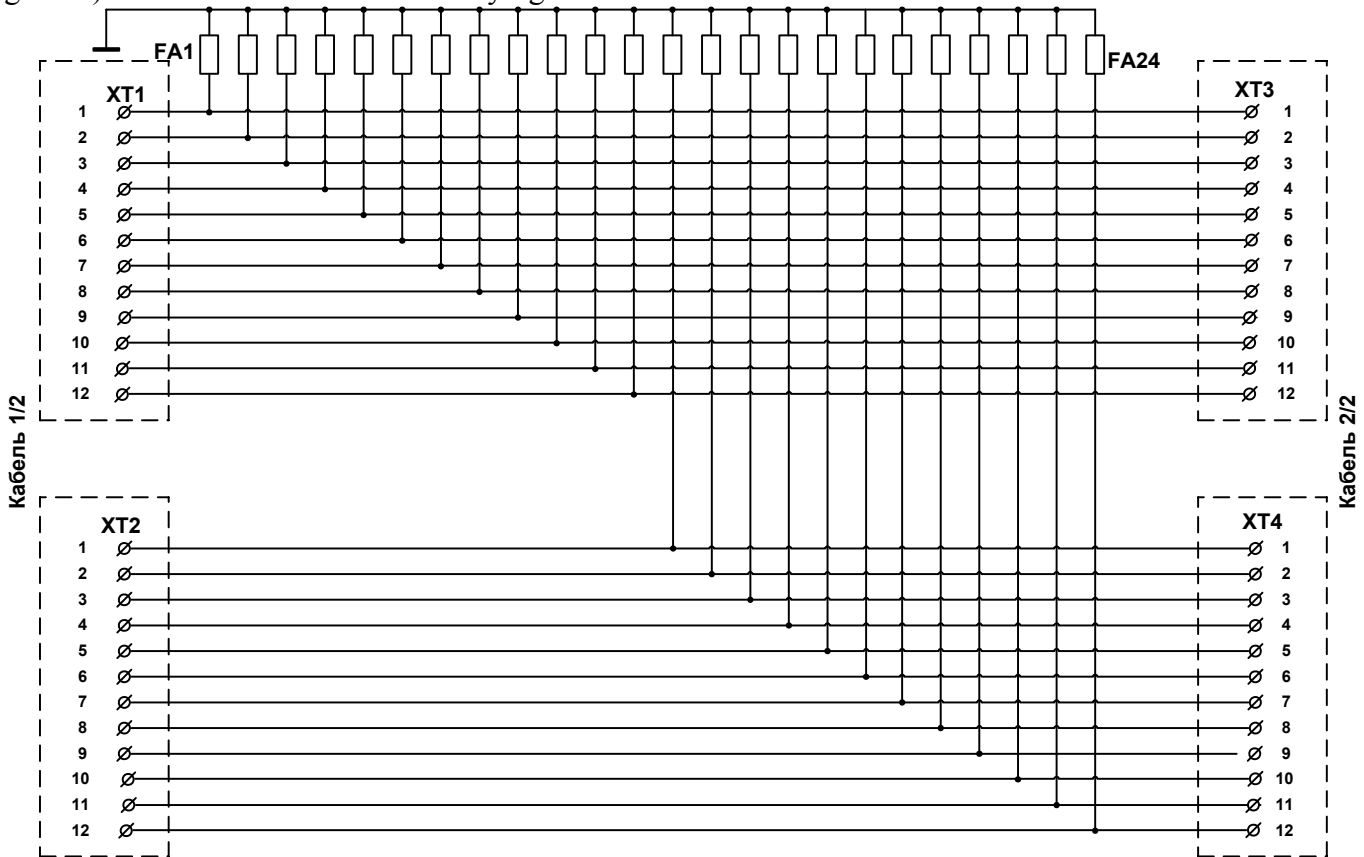

Fig. 6.15



Fig. 6.16

6.4.2.2 The CCU (CCU-P) (fig. 6.16) connection and control unit of “Impuls-mini1” (“Impuls-mini1/...P”) modifications is designed for connecting two RUs of adjacent wings and a CIU connection cable. Safe power supply voltage of the converter is 20 to 36VDC (11 to 36VDC for “P” modifications). The CCU (CCU-P) (fig. 6.17) is enclosed in a steel case 1 with removable housing 2. The housing is attached by means of two thin shank coarse thread screw 3. A tamper button is arranged in the upper part of the printed circuit board. When the housing is lifted a lever is released to open the contacts of the button.

A chassis 4 attached to the case. A printed circuit board 5 is attached to the back of the chassis. Access to “RU-LWg” and “RU-RWg” («БПМ-ЛФ» and «БПМ-ПФ») terminal sets to connect the RUs of the left and the right wings

on the printed circuit board is implemented through windows in the chassis. On the back of the chassis there are terminal sets to connect jumper wires arranged. In the base of the box there are glands lead-in 6 and 7 with a sleeves-nut 8 for connection cables of two RUs (6) and feeding a CIU (7) into the switching compartment, and a terminal to connect an earthing wire attached by means of a bolt. Earthing CCU is implemented through a terminal using an insulated cable of 3 to 4 mm in diameter.

A bracket 9 serving as a base of the case 1 provides for attaching the CCU to various surfaces (a barrier, a wall) or on poles and pipes. The marking shown in the fig. 6.18, fig. 6.19 may differ from that on the chassis

and the printed circuit board, but will provide information sufficient to make connections.

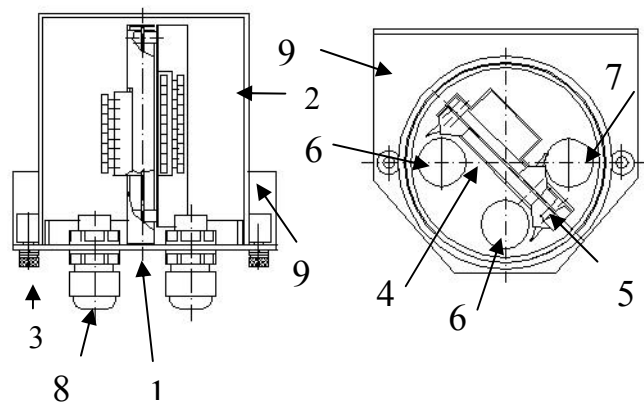

Fig. 6.17

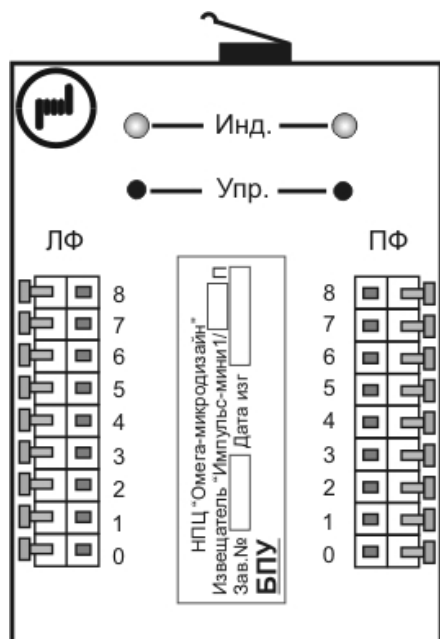

Fig. 6.18

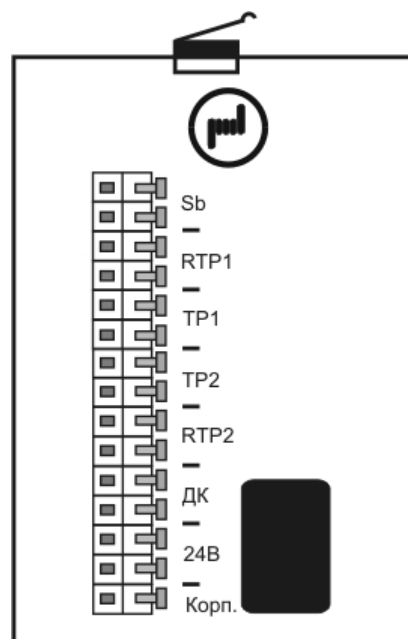

Fig. 6.19

The following is shown on the functional diagram of the CCU (fig. 6.20):

БПРМ-ЛФ (БПРМ-ПФ) - terminals to connect 8-conductor cables;

SB1 - a button that opens the circuit when the CCU cover is open;

XT1 - terminal to connect control resistors and jumper cables;

«TP1» (LWg), «TP2» (RWg) - alarm signal terminals to connect CIU;

«RTP1» (LWg), «RTP2» (RWg) - pairs of terminals to connect control (terminal) resistors that define the “monitoring” mode of the CIU;

«SB1» - terminals to connect unit’s cover status (opened/closed) buttons;

CY – control and power supply circuit (with indicator);

SB 2 «Упр-ЛФ» (SB 3 «Упр-ПФ») - control buttons;

HL1 «Инд-ЛФ» (HL2 «Инд-ПФ») - indicators;

«Сл1»...«Сл6» – service lines;

«24 В» - power supply (voltage of direct or alternating current);

«ДК» - Remote Control contacts. For protection from electromagnetic fields and inductions the shielding wire must be connected to terminals «0» («Корп»). At that the earthing terminal of the CCU case must be connected with the earthrod to provide secure operation and safe maintenance of the detector.

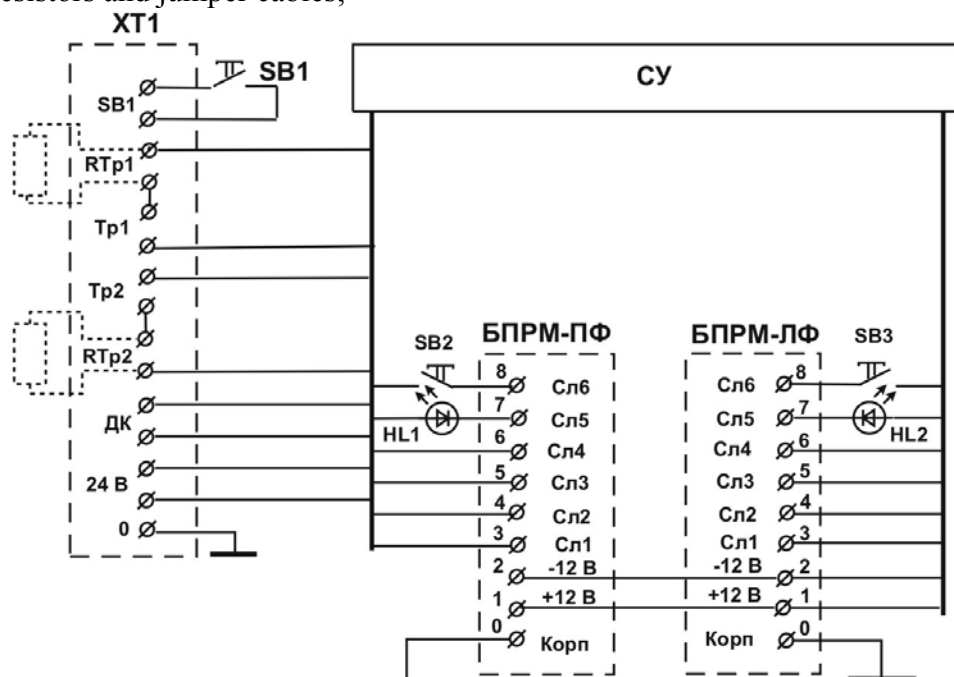

Fig. 6.20

## 7. MARKING AND SEALING

7.1 The detector’s units bear the following:

a manufacturer’s trademark; product code; year of manufacture.

7.2 One of the screws for fixing the panel to the detector’s RU box is placed into a suitable cup being sealed by the QC representative.

## 8. BOXING AND PACKAGE

8.1 Transportation boxes will have the handling marks as follows:

HANDLE WITH CARE, FRAGILE, KEEP DRY, TOP, DO NOT TURN OVER.

8.2 The transportation boxes will have a QC stamp by the manufacturer.

## 9. SAFETY PRECAUTIONS

9.1 Setting the detector up is done by two operators.

9.2 Maintenance of the detector must be carried out by personnel with strong skills in its operation and having a permission to work with electrical devices with voltage of up to 1000V.

9.3 It is necessary to remember that negligence in use of the detector and violation of the requirements of the present manual may cause failure of the detector.

9.4 When lines longer than 500 m are connected to the CCU's terminals, additional lightning protection must be installed to ensure draining of charges induced during lightning or other electrical charges.

9.5 It is prohibited to apply voltage higher than 38V to the CCU's terminals.

## 10. ORDER OF INSTALLATION

### 10.1 Installing on a barrier

10.1.1 Before the installation it is required to decide how the DA will form the guarded perimeter. Laying on internal and external corners, height variations or switching from one side of the barrier to the other, for example, when bypassing a wall of a building, shall be made in accordance with the fig.10.1 ... fig.10.4. It is necessary to provide smooth curves of the SU sections, by variation of attachment points and inclinations of consoles. It is also necessary to bear in mind that a large number of bends of the SU or proximity of the UW to conducting barriers will increase signal loss and reduce maximum permitted length of the guarded perimeter.

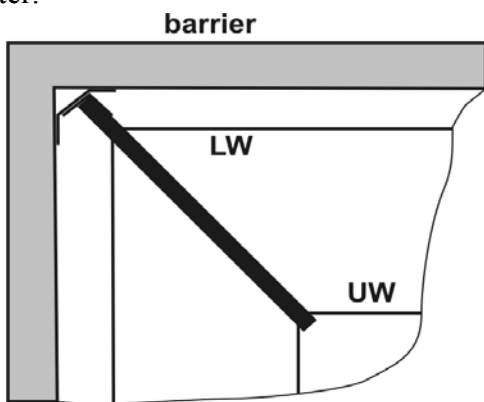

Fig. 10.1

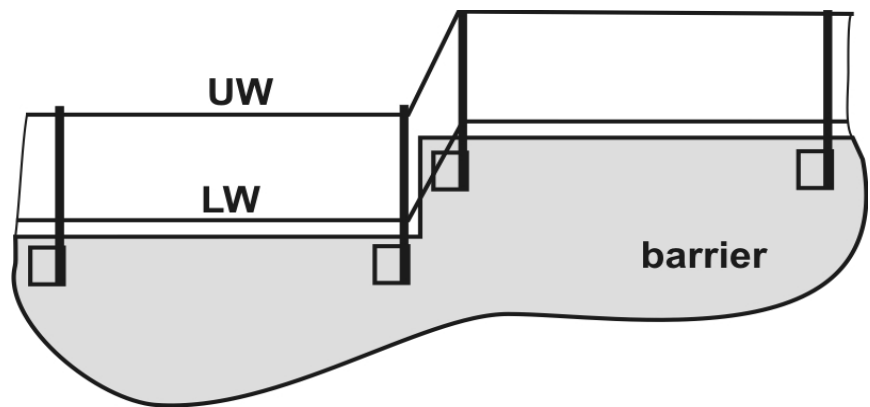

Fig. 10.2

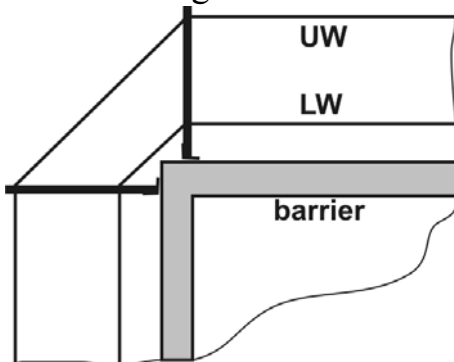

Fig. 10.3

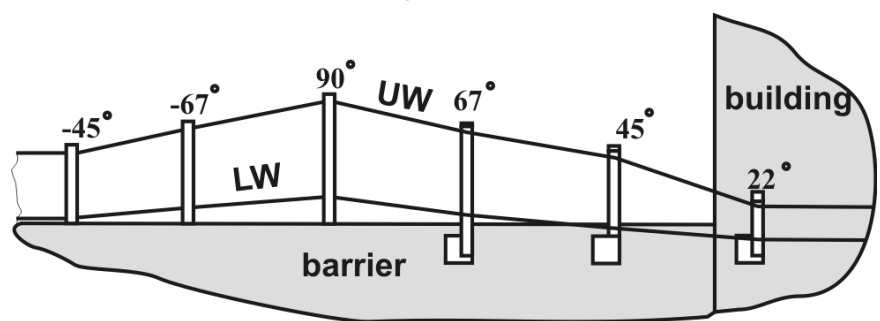

Fig. 10.4

10.1.2 Clean the barrier and the space within and near the DA from garbage (wires, steel sheets), remove interfering grass, bushes and branches of trees, fix wires and cables slack and swinging under wind.

10.1.3 Install the holders with dielectric consoles from the installation parts kit onto the barrier at intervals of ~3...5 meters. The holders 1 should to be attached to the barrier 3 by means of screws, bolts or other hardware 2 (fig.10.5). Install the dielectric console 4 onto the holder 1. Attach the LW 6 to the lower part of the console 4 by means of a clamp and screw (wood screw) 7. Attach the UW 8 to the upper part of the console in the same manner.

10.1.4 Attach the TU to the end holder of the guarded sector complying with the requirements of cl.6.4.1.2; attach the RU on the barrier near the attachment point of the UW on the start holder. The TU attachment plate 1 (see fig.10.6) is to be fixed on the console (support) by means of screws 3. If the console is installed vertically, the said plate shall be fixed

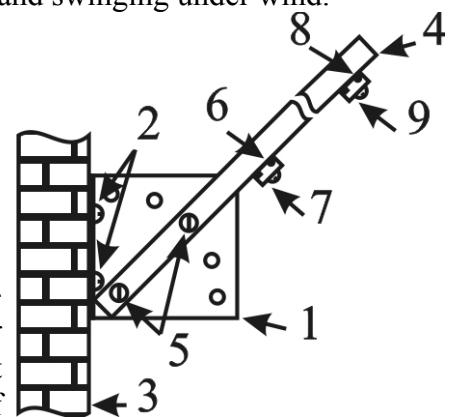

Fig. 10.5

so as the TU is under the lower (on the ground side) surface of the console. At that the console must not obstruct attaching the ground wire to the earthing terminal. Remove the sleeve-nut 5, run the UW 6 through the holes of the sleeve-nut 5, the washer and the rubber sleeve; remove the protective cap 7 and also run the UW 6 through the inner hole thereof, under which a contact for the UW connection is located; fix the UW to the proper contact; assemble in the inverse order. The same is to be done with the sleeve-nut 8, the LW 9 and the cap 10. Attach the UW and the LW to the bottom surface of the console by means of clamps and screws 11,12.

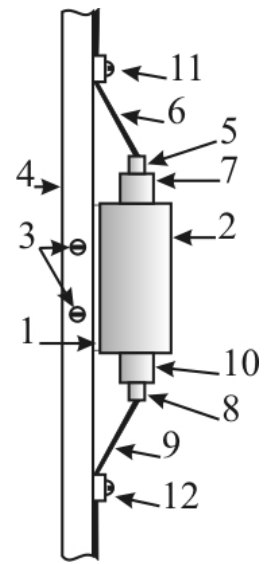

Fig. 10.6

10.1.5 If multiple detectors are installed serially the following recommendation to be taken into account. When installing adjacent TUs, maintain minimal inductive coupling between the wires and the earthrods of adjacent SUs of neighboring detectors. There are at least two ways of mounting end consoles with the adjacent detectors' TUs attached thereto on a barrier. Fig.10.7 and 10.8 show the end surfaces of the end consoles. The distance «A» between them must not be less than 200 to 300 mm. The SU1 and SU2 must not have parallel or crossing sectors, and must therefore have minimum inductive coupling (fig.10.9...10.11). In case of parallel installation the distances between the parallel SUs must not be less than a double distance between the upper and the power wires. All the TUs shall be connected to their own earthrods placed in the ground not closer than 500 mm to each other. An earthing conductor will be laid in downward direction along the console and further along the surface of the barrier (wall) to its own earthrod. An insulated wire of no less than 0.5 mm in diameter must be used as the earthing wire. No stringent requirements exist for closely located RUs of adjacent sectors provided they are connected to one and the same CCU. At that the RUs can be mounted as shown in Fig.10.7 to 10.11, or as shown in Fig.10.12 and earthed through a common earthrod. Unlike the TU, it is allowed not to connect a RU with the earthrod using a separate wire as the shield-

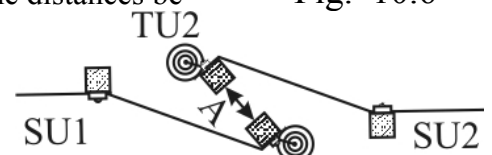

Fig. 10.7

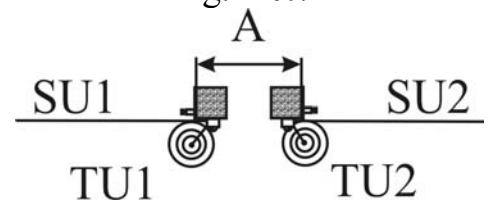

Fig. 10.8

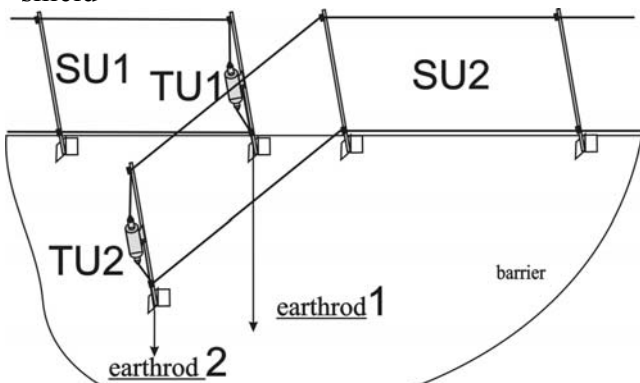

Fig. 10.9

ing band of the CCU connection cable serves as an earthing wire, where the said band is connected with the earthrod through the CCU. At that the CCU must be attached below or near (0.5 m distance as maximum) to the RU as to provide shortest connections from the RU to the earthrod. Installation of two RUs on one console is shown in the fig. 10.10 (console end top view). A connection cable will be laid along the console and further along the surface of a barrier (wall) to the CCU.

10.1.6 Earthrods or earth posts with a spreading resistance of no more than 30 Ohm shall be installed under the CCU and each RU.

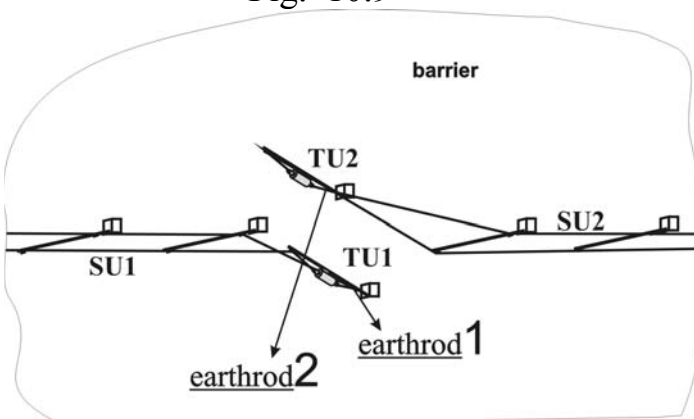

Fig. 10.10

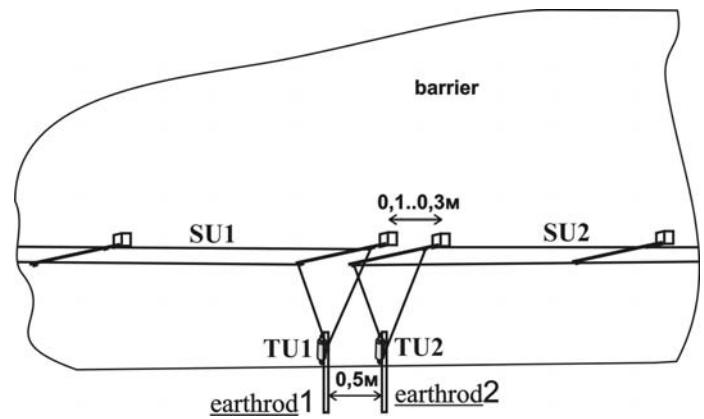

Fig. 10.11

10.1.7 The proper terminals of the units must be connected to earthrods. Unlike the TU, it is allowed not

to connect a RU with the earthrod using a separate wire as the shielding band of the CCU connection cable serves as an earthing wire. That will be allowed if the distance from the projection of RU to that of CCU onto the ground surface does not exceed 0.5 m. In such case the CCU is connected with the earthrod. Place the conductors, attach the cables to the chassis using suitable clamps, replace the removable chassis into the CCU and fix it by means of thin shank coarse thread screws.

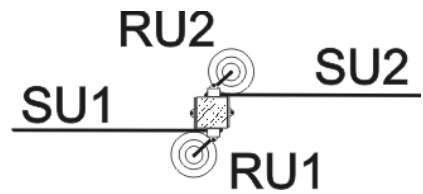

Fig. 10.12

10.1.8 Begin attaching the UW from the middle of the sector. The UW to be attached to the upper part of the console, strained simultaneously in opposite directions and attached to the upper parts of the neighboring dielectric consoles by means of clamps and screws. Repeat straining and attaching the UW in opposite directions towards the ends of the sector.

10.1.9 The LW, depending on the chosen limitations for the DA and maintenance policy, shall be attached: either in the lower part of the console, in parallel to the UW, or buried at a shallow depth in the ground to no more than 100 mm.

**Note. Sealing of the LW lead-in from moisture using a rubber washer shall not be done (see cl. 6.4.1.2). If the end consoles are located horizontally, for example, when using poles to attach the UW, the TU has to be attached either to the poles or to inclined terminal consoles, or to the earthrod.**

10.1.10 Prepare and lead the UW and LW into the TU and RU, as shown in the fig.10.18.

10.1.11 The distance between the neighboring units of adjacent sectors must exceed 200 mm, where the distance between the end consoles must exceed 300 mm.

10.1.12 When positioning the SU's wires of the adjacent TUs (not synchronizable units) of neighboring sectors provide as low as possible a capacitance coupling between them. For that purpose do not allow their parallel or close location (under any wind the wires must not approach each other closer than 100 mm) and the closest one to a perpendicular projections of their intersection.

## 10.2 Installation on an open ground

10.2.1 Fulfill works similar to those described in cl. 10.1.1 and cl. 10.1.2. Mark the perimeter at intervals of ~4...5 meters, dig holes of 300 × 300 × 600. Install holders into the holes (stubs from IPK4) at 90° to the ground surface leaving a visible part of 0.25 m, and fill the wholes with concrete or grout, as shown in the fig.10.13. After the grout sets, fix posts 1 to the holders 2 by means of screws 3, as shown in the fig.10.14.



Рис. 10.13

10.2.2 Strain the UW 1 applying a force of ~10 kg and attach (as per cl.10.1.8) sequentially in the upper parts of posts 4 using clamps 2 and screws 3 (see fig.10.15).

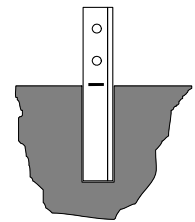

Рис. 10.14

10.2.3 Attach the LW to the lower parts of the supports with the same strain and fix with clamps and screws or bury into the ground to a depth of no more than 100 mm. Laying of the LW on the ground surface and fixing to the ground by means of clamps is allowed.

10.2.4 Install the SU using detached poles or trees by means of holders and consoles from IPK following steps in cl.10.1.

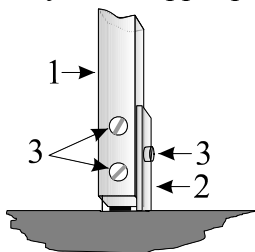

Рис. 10.15

10.2.5 Install earthrods into the ground leaving a visible part of 600 mm above the ground, at a distance of no longer than 1 m from end supports of the guarded sector. Attach TU and RU to posts (to earthrods, or to the surface of a wall of barrier for wall mount version) and connect the earthing terminals on the TUs' and RUs' boxes to terminals of the earthrods.

10.2.6 When guarding lengthy perimeters, where multiple detectors are installed in series, follow the fig.10.16 (a, b), fig.10.17 (a, b) to mark the adjacent SUs (SU1, SU2) closely located to the adjacent sectors. The distance "A" between the end posts of the adjacent SU1 and SU2 must **not be less than 500 mm**. It is necessary to maintain minimal inductive coupling between the wires and earthrods of adjacent SUs of the neighboring detectors. The earthing wire from the TU's terminal shall be laid along the post to the terminal on the support.

10.2.7 No stringent requirements exist for closely located RUs of adjacent sectors provided they are mutually synchronized. At that the can be earthed to a common earthrod.

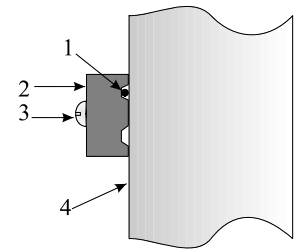
10.2.8 Install TU 2 on the end support in accordance with cl.10.1.4.



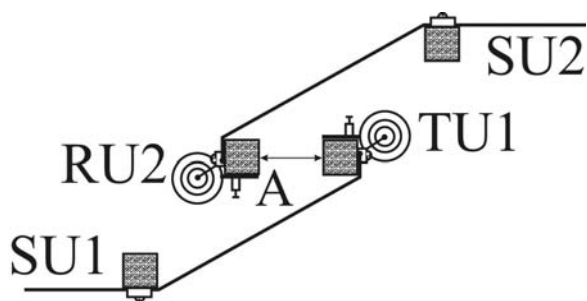

Fig. 10.16a

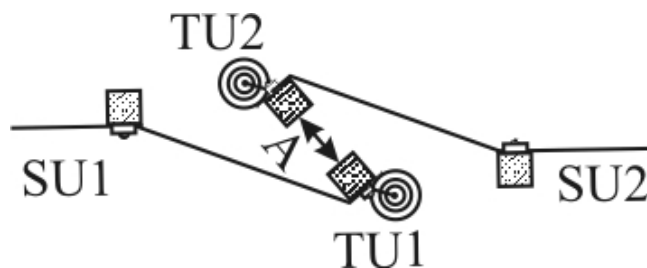

Fig. 10.16b

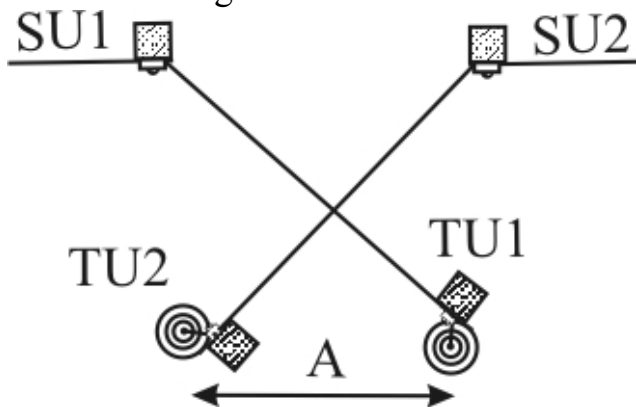

Fig. 10.17a

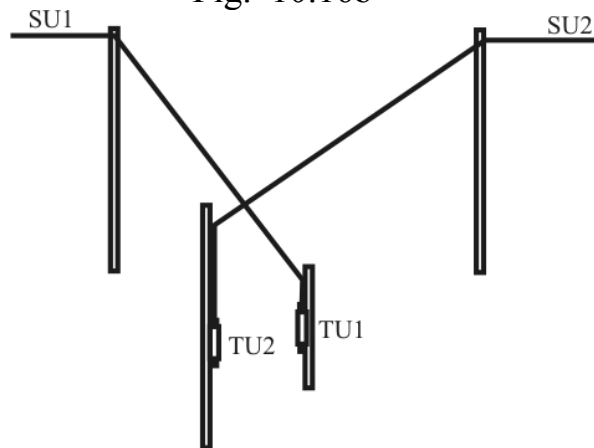

Fig. 10.17b

10.2.9 Remove two thin shank coarse thread screws and the CCU's cover. Lead the CIU connection cable into the switching compartment.

The "alarm signal" generated by the tamper button at the CCU cover can be combined with one of signals, for example "TP1", for which purpose the corresponding pair of control leads from the CIU shall be connected to the two terminals "TP1" and "SB», where a jumper shall be installed onto the other terminals.

### 10.3 Lead wires and cables

10.3.1 Prepare and lead the UW and LW into TU and RU as shown in the fig.10.18. Remove 10 mm of insulation coating at the ends of the wires, twist the lead veins and braise them. Remove the sleeve-nut 1, the washer 2, the rubber sleeve 3 (only for UW), and the cap 4. Install the removed parts over a wire in the order shown in the fig.10.18. Drive the screw 6 of the contact 7 several turns out; at that the pressure washer must move away from the surface of the contact making space for leading the brazed part of the wire 5 in. Lead the brazed part of the conductor 5 under the washer of the contact 7. Holding the wire 5 in this position fix it by the screw 6; curl the excess of the wire in the protective cap (see fig.10.16) and fully turn the said cap into place. Insert the rubber sleeve 3 (only for UW) and washer 2 into the hole of the protective cap 4; lead the excess of the wire in the protective cap hole and fully turn the sleeve nut 1 into place.

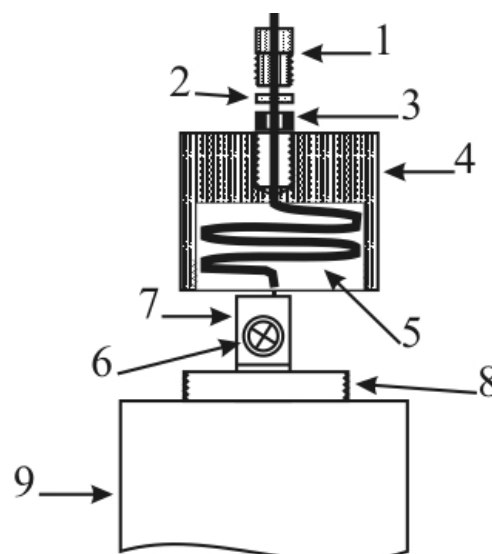

Fig. 10.18

*Note.* When installing the UW and the LW it is necessary to exclude draining of water over the wires into the RU and the TU, for which purpose form a loop of each wire before the lead-in.

10.3.2 Lead the RU's cable. The conductors of the cables shall be connected to the terminal sets marked as "RU-LWg" ("БПМ-ЛФ") and "RU-RWg" ("БПМ-ПФ") in accordance with table 10.1, fig. 10.19, fig. 10.22.

*Notes:* **terminal No.** – a number of a terminal in the groups at the CCU face plate; **b) ) pair No.** – a number of a twisted pair in the cable (numbers of twisted pair in the table are conventional). For reference use one of the colored conductors in the twisted pair, for example, orange/white shall be pair No.1, etc.); **c) if connecting only one wing use the "RWg"** (the right wing).

10.3.3 Lead the cable (power supply, DK, ALARM 1 и ALARM 2) into the switching compartment of the that purpose remove 100 mm of insulation and shielding from the cable, remove 15...20 mm of insulation of each conductor of the wire and braise them.

*Note.* If the outer diameter of the cable is less than 13 mm, wrap the cable with a PVC tape to obtain the diameter of 13.5 mm of the part, to which the rubber washer will be installed.

10.3.4 In accordance with the marking shown in fig. 10.19...10.22 connect the conductors of the cable to the contacts of the RU's terminals and carefully pack the conductors. To connect the conductors of the cable press the clamp lever, insert the exposed end of a conductor into the opened hole and release the lever.

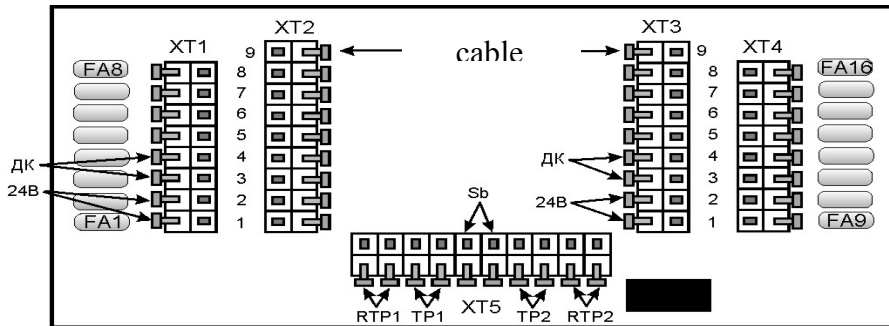

Fig. 10.20

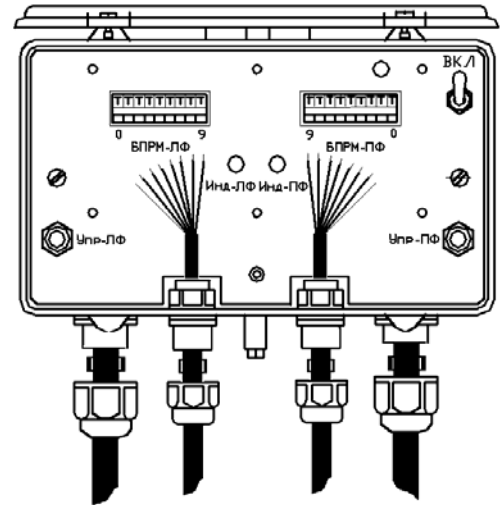

Fig. 10.19

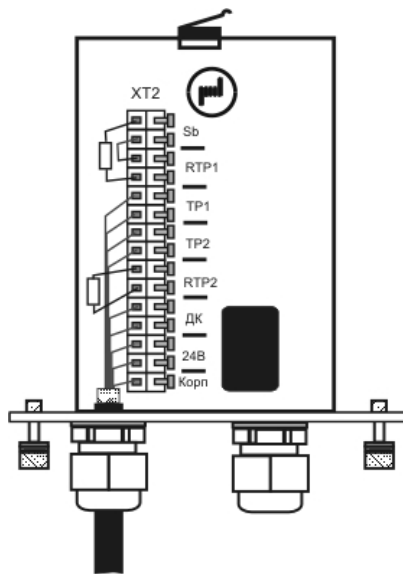

Fig. 10.21

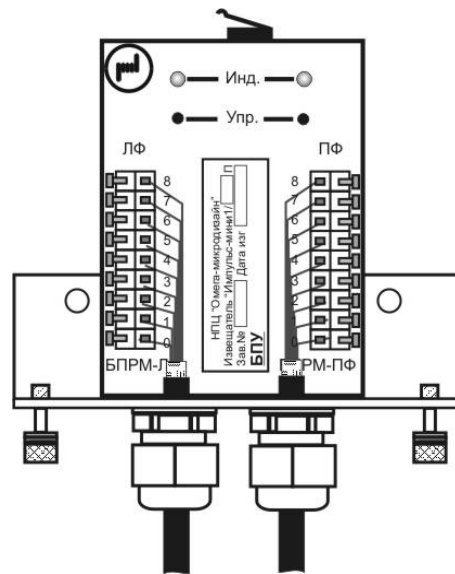

Fig. 10.22

Table 10.1

Pair No.	Conductor color	Terminal No.	Circuit designation
1	<b>orange</b>	<b>1</b>	+ 12V
	<b>white</b>	<b>5</b>	Service 3
2	<b>brown</b>	<b>3</b>	Service 1
	<b>white</b>	<b>2</b>	- 12V
3	<b>blue</b>	<b>6</b>	Service 4
	<b>white</b>	<b>8</b>	Service 6
4	<b>green</b>	<b>7</b>	Service 5
	<b>white</b>	<b>4</b>	Service 2
<b>Shield wire</b>		<b>0</b>	Ground (case)

## **11. SETTING UP THE DETECTOR**

### **11.1 Testing of power supplies of the detector**

11.1.1 Setting up the detector is done by two operators, who have permissions to work with electrical devices with voltage of up to 1000V.

11.1.2 Setting up shall be carried out after installation of the RUs, TUs and CCU on a solid bearing surface (a wall, a fence, a console, a pole, an earthrod, etc.), attaching and connecting the SU's wires, earthing and external synchronization, laying and connecting the power supply and alarm cables.

11.1.3 Remove the CCU cover.

11.1.4 Apply the power supply voltage to the "24 B" terminals 24V; at that the indicators of the connected wings must simultaneously go on and then off.

On the CCU panel the indicators corresponding to the wings must be pulsing (flashing).

### **11.2 Functional test and adjustment of the detector**

11.2.1 The operators will stand within a line of sight, one at the CCU and the other at a distance of 5 m from the SU (initial position).

11.2.2 In 1 minute after the power supply is turned on the detector will go into a MONITORING MODE, in which the indicators on the face panel of the CCU are off.

11.2.3 If the MONITORING MODE does not activate, turn the power off and remove possible faults and repeat steps in cl.11.2.1, cl.11.2.2.

11.2.4 Test the detector in a DK mode, for which purpose by means of a button of the warning panel or in other manner temporarily, for 1 to 2 seconds, apply a voltage of 12 to 36 V to the DK's terminals. In response to the signal from the DK the detector must generate an ALARM signal, indicators on the face panel of the CCU must go on and off for 8 times.

### **11.3 Training of the detector**

11.3.1 Select the training mode based on explanation in cl.11.4. The operator at the CCU will activate the training mode. For that press and hold a relevant button "Упр..." until the indicator goes on and off for 1 or 2 times, then release the button (cl.11.4).

*Notes. This type of detector does not provide for manual setting and indication of threshold values, but can be set in a semi-automatic mode. While one of the operators crosses the DA, the other will press the «Упр-ЛФ» ("Ctrl-LWg") or «Упр-ПФ» ("Ctrl-RWg") button on the CCU for a short time to generate the required operating event for the detector. Correct setting will be checked by means of test passes in the monitoring mode. Prior to the start of training the detector the spatial DA should be visualized to define possible distortions caused by various obstructions at the guarded perimeter. Consider the ways of passing the DA. As an example, below is a procedure for adjustment of a detector with a DA formed above the ground surface without barriers.*

11.3.2 The operators will stand within a line of sight, one at the CCU and the other at a distance of 5 m from the SU (initial position).

11.3.3 The operator at the CCU will wait until the indicator of the wing being adjusted goes off and request the operator at the perimeter to start passing the DA.

11.3.4 The operator at the SU will start passing the perimeter in "all the way" posture at a maximum possible rate. As soon as the center line of the DA is reached, the operator at the CCU will press the button for a short-time and then release it. Blinking of the indicator four times at short equal intervals after the button is released will mean acceptance of the threshold, where no blinking will mean denial of the threshold acceptance, for example, due to proximity of the threshold to a noise signal. The operator at the SU will leave the guarder area immediately after the button is pressed by the operator at the CCU to position himself at a distance of no less than 5 m from the SU wires.

11.3.5 Repeat steps 11.3.2 to 11.3.4 at different sectors of the perimeter in various postures ("all the way", "two-double", "on haunches"), where the operator must cross the DA. After each pass the operator at the SU will return to his initial position and move along the perimeter at a distance of no less than 5 m from the SU wires.

11.3.6 For the "canopy-type" version the passing must be in accordance with cl. 11.3.2 to 11.3.5 using any manner, between the SU wires, where the operator must cross the DA. At each time the operator's center of gravity comes in between the SU wires, the operator at the CCU will press the button for a short time.

11.3.7 Upon completion of thresholds\* setting, press and hold the relevant button until the second activation of the indicator. Blinking of the indicator eight times after the button is released means that the settings have been saved.

*\*Note. If for any reason saving of the training settings (the thresholds selected) is not required, press and hold the button until the third activation of the indicator. As soon as the button is released the indicator will go on and then off, and the settings will not be saved.*

## 11.4 Detector training procedure

11.4.1 Verify that no people or animals are present within a distance of 5 m from the SU. Stand at the CCU so that the operation of the indicators and pressing the buttons on the face panel can be easily observed and done. Make a pause of 3 to 5 minutes.

*Notes. Make pauses between the operator's approaches to the SU of 2 to 3 minutes, standing in the initial position. If the CCU is close to the DA, the operator at the CCU will constantly (not releasing) touch the button and not move during the training so as not to affect generation of the signal.*

11.4.2 Switch the detector into TRAINING mode (TRAINING1 – “complementary training”, done in case of increase of the detector's sensitivity; TRAINING2 – “retraining”, done in case of decrease or increase of the detector's sensitivity). For that press and hold a relevant button “Ctrl-LWg (Ctrl-RWg)”. Count a number of the intermittent operations of a relevant indicator “Ctrl-LWg (Ctrl-RWg)” and release the button immediately after the first (TRAINING1) or the second (TRAINING2) operation of the indicator. If the button is released after the third time the “Ind-LWg (Ind-RWg)” indicator goes on, the detector will be RESET with further switching into the monitoring mode.

11.4.3 After the “Ind-LWg (Ind-RWg)” goes off\* request the operator at the SU to cross the guarded perimeter in both directions in “all the way”, “two-double”, and “on haunches” postures (for the canopy-type version – between the SU's wires in any position) at a maximum possible rate, making a pause of 2 to 3 minutes between the passes. As soon as the operator at the SU reaches the center line of the DA, the operator at the CCU will press and release a “Ctrl-LWg (Ctrl-RWg)” button corresponding to the wing. Upon completion of training press the button and hold it until the second indicator goes on for the second time (SAVE mode with further switching to the monitoring mode). If the button is not released before the indicator goes on for the third time (RESET mode) the detector will be RESET with further switching into the monitoring mode and the training setting will not be saved.

*\*Notes: In the TRAINING (COMPLEMENTARY TRAINING) mode a transient operation (“pulsing”) of the indicator is allowed. In case of frequent operation of the indicator, the operator at the perimeter should move away from the SU wires to a distance of more than 5 m; the operator at the CCU should observe the indicators standing still for several minutes. The “Ind-LWg (Ind-RWg)” indicator must not spontaneously illuminate or blink. Otherwise define and fix the source of noise.*

### The detector is now operating in the MONITORING MODE

## 11.5 Testing of the detector

11.5.1 The operator at the perimeter will cross it at any locations and in various postures (“all the way”, “two-double”, “on haunches”), where the operator must cross the DA. After each operation of alarm indicators, the operator at the perimeter will immediately move away from the center line to a distance of no less than 5 m.

11.5.2 The operator at the CCU will observe generation of ALARM signals and record distances between the other operator and the UW at each occurrence of an ALARM signal.

11.5.3 The operator at the SU will repeat the passes of the guarded perimeter. Make pauses between the operator's approaches to the SU of 2 to 3 minutes, standing in the initial position.

11.5.4 The operator at the SU will make attempts to cross the DA with intervals of 2 to 3 minutes at various locations of the guarded perimeter. After each passing the operator at the perimeter will leave the guarded area, and the operator at the CCU will recognize generation of an alarm signal by intermittent illumination of a relevant indicator.

11.5.5 For the near-the-ground version without a barrier define a width of the DA by requesting the operator at the SU to cross the perimeter in “all the way” posture. Upon occurrence of an alarm signal stop the operator at the SU; the distance from the operator to the UW of the SU must not exceed 0.75 m (for the DA width = 2 m). If the measured distance exceeds 0.75 m, retrain the wing.

11.5.6 Close the CCU cover and test the safe operation of the detector by monitoring the signals of operation using the CIU.

11.5.7 In case of false operations of the detector readjust the relevant wing and test run the detector.

## **12. MAINTENANCE SCHEDULE**

### 12.1 General provisions

12.1.1 The present maintenance schedule is the main document that defines types, content, intervals and technique of the scheduled works on the detector.

12.1.2 Maintenance will mean measures to control health of the detector and maintain it in good order.

12.1.3 Timely and complete maintenance during operation is one of the basic requirements in supporting the good working condition of the detector.

12.1.4 Maintenance of the detector provides for a scheduled completion of a package of preventive works comprising the following routines:

Routine 1 – daily maintenance;

Routine 2 – monthly maintenance;

Routine 3 – semiannual maintenance.

### 12.2. List of maintenance operations

#### 12.2.1 Routine 1:

visual inspection of detector;

functional test of detector.

#### 12.2.2 Routine 2:

visual inspection of detector;

functional test of detector;

checking of lubricant at hardware of detector units;

inspection of fastening of SU elements;

inspection of service documentation.

#### 12.2.3 Routine 3:

visual inspection of detector;

functional test of detector;

checking lubricant at hardware of detector units;

inspection of SU elements fastening;

inspection of service documentation;

inspection of SU wires and connector cables condition.

### 12.3 Procedure of maintenance operations.

#### 12.3.1 Visual inspection of detector.

##### 12.3.1.1 During visual inspection check for:

tightness of unit box covers;

damage of paint or corrosion marks;

tears and cuts on SU wires and connector cables;

wire slacks of more than 50 mm;

icing on SU wires;

security of attachment of detector units.

#### 12.3.2 Functional test of detector.

12.3.2.1 The operators will stand within a line of sight, one at CCU and the other at SU.

12.3.2.2 The operator at SU will make attempts to cross the guarded perimeter at various locations of the perimeter. After each pass the operator will monitor generation of an alarm signal. Repeat the attempts in 2 to 3 minutes. In the alarm mode indicator 4 on the face panel of the RU is on.

#### 12.3.3 Checking lubricant at hardware of detector units.

12.3.3.1 Check presence of lubricant at pins and nuts, by which means the detector's SU units and holders are attached. Is necessary, apply lubricant coat (type K-17, CIATIM-201, petroleum jelly).

#### 12.3.4 Inspection of SU elements fastening .

12.3.4.1 Check fastening of holders, tighten securely if necessary.

12.3.4.2 Check attachment of wires to dielectric consoles, tighten if necessary.

#### 12.3.5 Inspection of service documentation.

12.3.5.1 Check availability of the manual.

#### 12.3.6 Inspection of SU wires and connector cables condition.

12.3.6.1 Turn the power supply off.

12.3.6.2 Disconnect all wires from detector units.

12.3.6.3 Wash with ethyl alcohol (GOST 18300-87) in accordance with the standing application rates.

12.3.6.4 Using a megohmmeter with working voltage of up to 500V measure a resistance between the conductors and resistance to earthrod. The resistance must not be less than 0.5 MOhm.

12.3.6.5 Connect all cables and wires to detector units according to the electrical diagram and close the units.

12.4 The following is required to carry out the scheduled work: multimeter C4313 or other device with equal or better characteristics; a megohmmeter with working voltage of up to 500V; screw drivers; spanner 7811-0457 GOST 2839-80; combination pliers; wire cutters; a ladder; a 500 gr hammer; a brazing torch; entrenching tools; rag; lubricant (type K-17, CIATIM-201, petroleum jelly GOST 15975-70); ethyl alcohol (GOST 18300-87); kerosene.

### **13. STORAGE AND TRANSPORTATION RULES**

13.1 A detector shall be stored in a manufacturer's package in accordance with storage conditions clause 3 (a non heated storage facility) GOST 15150-69.

“Machines, devices and mechanical articles. Constructions for various climatic conditions. Categories, operating, storage and transportation conditions related to action of climatic environmental factors in absence of corrodent vapors”.

13.2 Transportation of detectors in the manufacture's package must be conducted in a pressure compartment of an aircraft, in railway box wagons or containers without a limitation of distance, in road vehicles on unpaved roads at a speed of 40 km/hr to a distance of 1000 km.

Note. When transporting by railway low-tonnage shipment must be used.

### **14. TROUBLESHOOTING**

Description and characteristics of fault	Possible reason	Remedy
1. None of the indicators of the CCU panel is on	a) No power supply voltage b) cables connected incorrectly	a) Repair cable fault b) check correctness of connections
2. ALARM signal is continuously generated 2.1 Indicators of the CCU panel are on	a) open or short circuit of upper or lower wire b) total length of line exceeds that indicated in cl.3.2 c) power supply voltage is less than that required by cl.3.5. d) SU length is less than that is mentioned in cl. 3.2	a) restore integrity of SU wires b) make SU length compliant to cl.3.2 c) make power supply voltage compliant to cl.3.5. d) Make SU length compliant to cl.3.2
3. Frequent false operations	a) high-noise condition due to violation of sections 4 and 10. b) sensitivity of device set too high when adjusted as per cl.11.4.	a) Follow steps in sections 4 and 10. b) Adjust sensitivity as per cl.11.4.
4. Detector not always generates an ALARM signal when perimeter is crossed	a) instructions not observed for installation of SU and formation of DA as required by section 4 and cl. 4.2...4.8 b) sensitivity of device set too low when adjusted as per cl.11.4.	a) Match the required dimensions and shape of DA as required by section 4 and cl. 4.2...4.8 b) Adjust sensitivity as per cl.11.4.

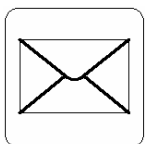

**RUSSIA, 12, Gladkova str.  
440600, Penza**

**[info@TSO-perimetr.ru](mailto:info@TSO-perimetr.ru)  
[www.TSO-perimetr.ru](http://www.TSO-perimetr.ru)**

**Phone /Fax  
(+7) 8412-54-1268,  
Phone  
(+7)495-764-1826**



E-mail: **[info@TSO-perimetr.ru](mailto:info@TSO-perimetr.ru)**  
http//: **[www.TSO-perimetr.ru](http://www.TSO-perimetr.ru)**  
**[ICQ: 541202](https://www.icq.com/lookup?number=541202)**    **[Skype: TSO-perimetr](https://www.skype.com/lookup?name=TSO-perimetr)**